

Application

Designed for installation on potable water lines to protect against both backsiphonage and backpressure of contaminated water into the potable water supply. The Model 375 provides protection where a potential health hazard exists. Ideal for use where lead-free* valves are required

Standards Compliance

(Unless Otherwise Noted, Sizes 2 1/2" Thru 10")

- ASSE® Listed 1013
- IAPMO® Listed
- Certified to NSF/ANSI 372* by IAPMO R&T
- CSA® Certified B64.4 (2 1/2" thru 8")
- AWWA Compliant C511, and C550
- FM® Approved
- UL® Classified
- C-UL® Classified
- NYC MEA 49-01-M Vol 2
- Approved by the Foundation for Cross Connection Control and Hydraulic Research at the University of Southern California.
- NSF® Listed-Standard 61, Annex G*

*(0.25% MAX. WEIGHTED AVERAGE LEAD CONTENT)

Materials

Main valve body	Ductile Iron ASTM A 536 Grade 4
Access covers	Ductile Iron ASTM A 536 Grade 4
Coatings	FDA Approved fusion epoxy finish
Internals	Stainless steel, 300 Series NORYL™, NSF Listed
Fasteners	Stainless Steel, 300 Series
Seal rings	EPDM (FDA approved)
O-rings	Buna Nitrile (FDA approved)
Springs	Stainless Steel, 300 Series
Sensing line	Stainless Steel, braided hose

Features

Sizes:	2 1/2", 3", 4", 6", 8", 10"
Maximum working water pressure	175 PSI
Maximum working water temperature	140°F
Hydrostatic test pressure	350 PSI
End connections (Grooved for steel pipe)	AWWA C606
(Flanged)	ANSI B16.1 Class 125

Relief Valve discharge port:

2 1/2" - 6"	-	2.75 sq. in.
8" - 10"	-	3.69 sq. in.

Attention: Model 375 (flange body) and Model 375A (grooved body) have different lay lengths.



Options

(Suffixes can be combined)

- with NRS shut-off valves (standard)
- FS - with cast iron wye type strainer (flanged only)
- FSC - with epoxy coated wye type strainer (flanged only)
- G - with grooved end NRS gate valves
- GF - with grooved inlet gate connection and flanged outlet gate connection
- FG - with flanged inlet gate connection and grooved outlet gate connection
- L - less shut-off valves (flanged body connections)
- MS - with Integral Relief Valve Monitor Switch
- OSY - with OS&Y gate valves
- PI - with Post Indicator gate valve (3" - 10")
- DOM - with Clow gate valves, 51% Buy American Act Compliant

Accessories

- Repair kit (rubber only)
- Thermal expansion tank (Model XT)
- OS & Y Gate valve tamper switch (OSY-40)
- Air gap (Model AG)
- Electronic Solenoid Timer (Model EST)
- QT-SET Quick Test Fitting Set

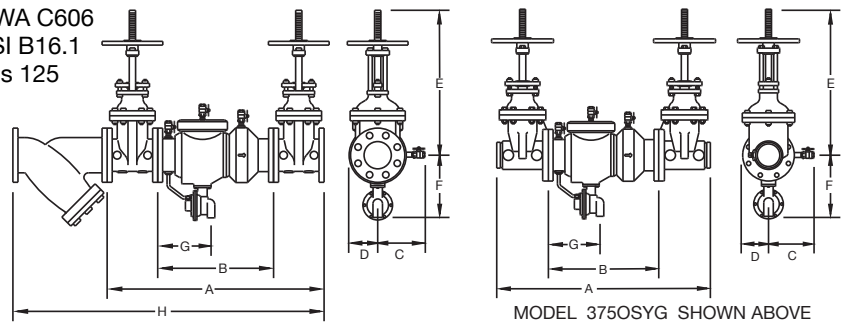

Dimensions & Weights (do not include pkg.)

MODEL 375 SIZE	DIMENSION (approximate)											WEIGHT															
	A		B LESS GATE VALVES		C		D		E OS&Y OPEN		E OS&Y CLOSED		E NRS GATE		F		G		H		WITHOUT GATE VALVES		WITH NRS VALVES		WITH OS&Y GATE VALVES		
	in.	mm	in.	mm	in.	mm	in.	mm	in.	mm	in.	mm	in.	mm	in.	mm	in.	mm	in.	mm	lbs.	kg	lbs.	kg	lbs.	kg	
2 1/2	65	31	787	15 7/8	403	7 1/4	184	3 3/4	95	11 3/8	289	11 3/8	289	9 1/2	241	8 3/8	213	41 1/4	1048	60	27.2	162	73.5	170	77.2		
3	80	32	813	15 7/8	403	7 1/4	184	3 3/4	95	11 3/8	289	11 3/8	289	9 1/2	241	8 3/8	213	42 3/4	1086	60	27.2	184	83.5	190	86.3		
4	100	37 5/8	956	19 1/2	495	8	203	4 1/2	114	22 3/4	578	18 1/4	464	14 3/4	375	11	279	9 1/4	235	52 3/4	1340	98	44.5	278	126.5	288	130.8
6	150	44 3/4	1137	23 1/2	597	10	254	6	152	30 1/8	765	23 3/4	603	19	483	12 3/8	314	10 3/4	273	62 3/4	1594	175	79.5	459	208.4	475	215.6
8	200	60 3/4	1543	37 3/4	959	11	279	10	254	37 3/4	959	29 1/4	743	22 1/2	572	15 3/8	391	16 3/4	426	85	2159	377	171	829	376.4	853	387.3
10	250	63 3/4	1619	37 3/4	959	11	279	10	254	45 3/4	1162	35 3/8	899	26 1/2	673	15 3/8	391	16 3/4	426	93 1/4	2369	407	185	1167	530	1225	556

MODEL 375 2 1/2", 3" & 4" (STANDARD & METRIC)

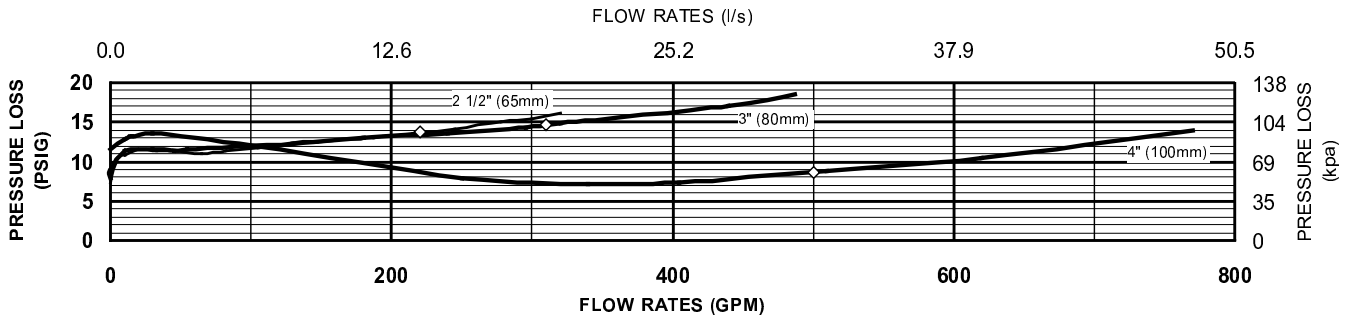

MODEL 375 6", 8" & 10" (STANDARD & METRIC)

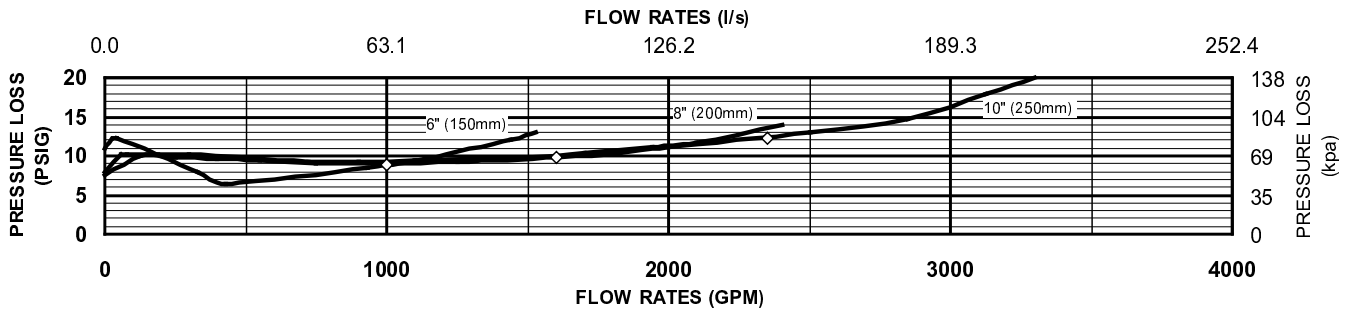

Typical Installation

Local codes shall govern installation requirements. Unless otherwise specified, the assembly shall be mounted at a minimum of 12" (305mm) and a maximum of 30" (762mm) above adequate drains with sufficient side clearance for testing and maintenance. The installation shall be made so that no part of the unit can be submerged.

Capacity thru Schedule 40 Pipe (GPM)				
Pipe size	5 ft/sec	7.5 ft/sec	10 ft/sec	15 ft/sec
2 1/2"	75	112	149	224
3"	115	173	230	346
4"	198	298	397	595
6"	450	675	900	1351
8"	780	1169	1559	2339
10"	1229	1843	2458	3687
12"	1763	2644	3525	5288

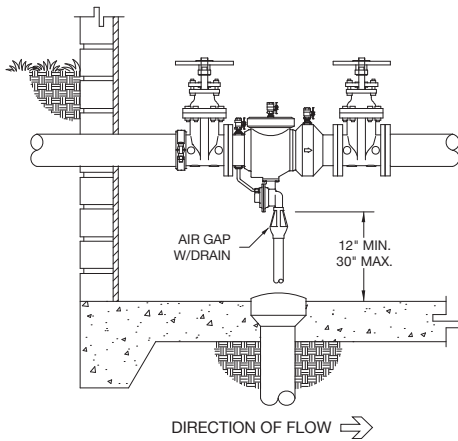

INDOOR INSTALLATION (375GF)

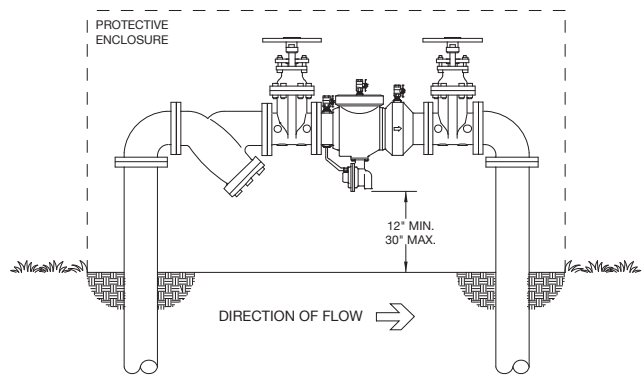

OUTDOOR INSTALLATION

Specifications

The Reduced Pressure Principle Backflow Prevention Assembly shall be certified to NSF/ANSI 372, ASSE® Listed 1013, and supplied with full port gate valves. The main body and access cover shall be epoxy coated ductile iron (ASTM A 536 Grade 4), the seat ring and check valve shall be NORYL™, the stem shall be stainless steel (ASTM A 276) and the seat disc elastomers shall be EPDM. The checks and the relief valve shall be accessible for maintenance without removing the device from the line. The Reduced Pressure Principle Backflow Prevention Assembly shall be a ZURN WILKINS Model 375.