

Application

Designed for installation on water lines to protect against both backsiphonage and backpressure of contaminated water into the potable water supply. Elbows allow for a very small installation footprint for confined spaces or landscaping. Assembly shall provide protection where a potential health hazard exists.

Standards Compliance

- ASSE® Listed 1013
- IAPMO® Listed
- CSA® Certified
- AWWA compliant C511
- NYC MEA 110-01-M
- Approved by the Foundation for Cross Connection Control and Hydraulic Research at the University of Southern California

Materials

Main valve body	Cast Bronze ASTM B 584
Access covers	Cast Bronze ASTM B 584
Elbows	Cast Bronze ASTM B 584
Fasteners	Stainless Steel, 300 Series
Elastomers	Silicone (FDA approved) Buna Nitrile (FDA approved)
Polymers	Noryl™, NSF Listed
Springs	Stainless steel, 300 series
Ball valve handles	Nickle plated carbon steel

Features

Sizes:	3/4", 1", 1-1/4", 1-1/2", 2"
Maximum working water pressure	175 PSI
Maximum working water temperature	180°F
Hydrostatic test pressure	350 PSI
End connections Threaded	ANSI B1.20.1

Relief Valve discharge port:	
3/4" - 1"	- 0.63 sq. in.
1 1/4" - 2"	- 1.19 sq. in.

Dimensions & Weights (do not include pkg.)

MODEL SIZE		DIMENSIONS (approximate)														WEIGHT	
		A		B		C		D		E		F		F UNION BALL VALVES			
in.	mm	in.	mm	in.	mm	in.	mm	in.	mm	in.	mm	in.	mm	in.	mm	lbs.	kg
3/4	20	11 5/8	295	2 1/8	54	3	76	3 1/2	89	5	127	5 13/16	148	6 7/8	175	14	6.4
1	25	11 5/8	295	2 1/8	54	3	76	3 1/2	89	5	127	6 5/16	160	7 1/4	184	15	6.8
1 1/4	32	13 5/16	338	2 3/4	70	3 1/2	89	5	127	6 3/4	171	N/A	N/A	6 5/16	160	29	13.2
1 1/2	40	13 1/2	343	2 3/4	70	3 1/2	89	5	127	6 3/4	171	N/A	N/A	7 1/2	191	29	13.2
2	50	14 5/16	364	2 3/4	70	3 1/2	89	5	127	6 3/4	171	N/A	N/A	8 5/8	219	36	16.3



Size 3/4"-1"
(975XLSE)

Size 1-1/4"-2"
(975XLSEU)

Options

(Suffixes can be combined)

- with full port QT ball valves (3/4" - 1" standard)
- U - with full port QT union ball valves (1 1/4" - 2" standard)
- SH - with stainless steel ball valve handles

Accessories

- Air gap (Model AG)
- Repair kits (rubber only)
- Thermal expansion tank (Mdl. XT)
- Soft seated check valve (Model 40XL2)
- Shock arrester (Model 1250XL)
- QT-SET Quick Test Fitting Set

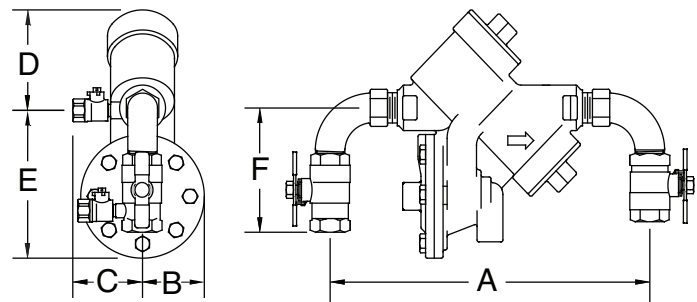

MODEL 975XLSE 3/4", 1", 1-1/4", 1-1/2" & 2" (STANDARD & METRIC)

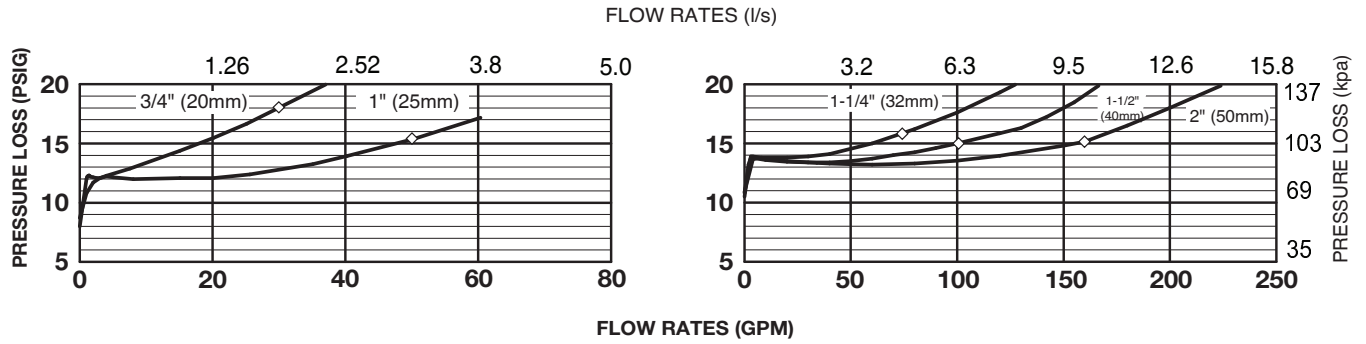

Typical Installation

Local codes shall govern installation requirements. To be installed in accordance with the manufacturers' instructions and the latest edition of the Uniform Plumbing Code. Unless otherwise specified, the assembly shall be mounted at a minimum of 12" (305mm) and a maximum of 30" (762mm) above adequate drains with sufficient side clearance for testing and maintenance. The installation shall be made so that no part of the unit can be submerged.

Capacity thru Schedule 40 Pipe				
Pipe size	5 ft/sec	7.5 ft/sec	10 ft/sec	15 ft/sec
1/8"	1	1	2	3
1/4"	2	2	3	5
3/8"	3	4	6	9
1/2"	5	7	9	14
3/4"	8	12	17	25
1"	13	20	27	40
1 1/4"	23	35	47	70
1 1/2"	32	48	63	95
2"	52	78	105	167

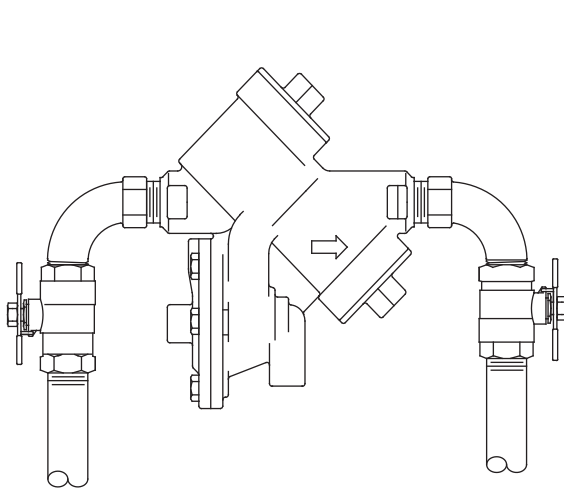

DIRECTION OF FLOW →

TYPICAL INSTALLATION

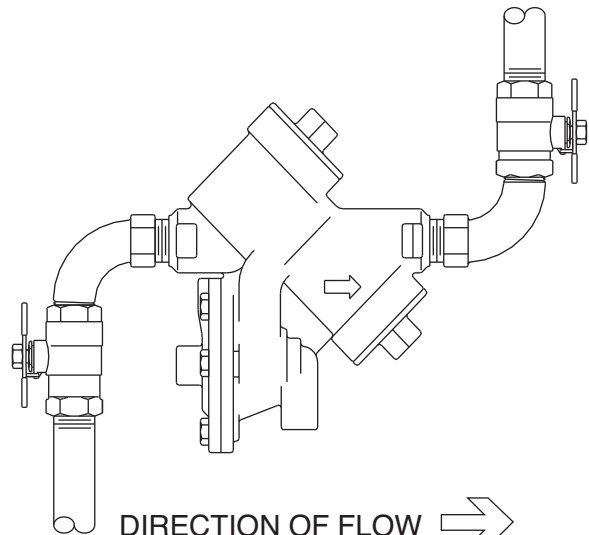

DIRECTION OF FLOW →

TYPICAL INSTALLATION

Specifications

The Reduced Pressure Principle Backflow Preventer shall be rated to 180°F and fully assembled with 90° street elbows and full port ball valves. The main body, access covers and elbows shall be bronze (ASTM B 584), the seat ring and all internal polymers shall be NSF® Listed Noryl™. The seat disc elastomers shall be silicone. The first and second check valves shall be accessible for maintenance without removing the relief valve or the entire device from the line. If installed indoors, the installation shall be supplied with an air gap adapter. The Reduced Pressure Principle Backflow Preventer shall be a ZURN WILKINS Model 975XLSE.