

Maxim™ Series LFM500, LFM500N, LFM500Z



Reduced Pressure Detector Assemblies

Sizes: 2 1/2" – 10"

LEAD FREE*



LFM500 OSY



LFM500N OSY

Features

- Extremely Compact Design
- 70% Lighter than Traditional Designs
- 304 (Schedule 40) Stainless Steel Housing & Sleeve
- Groove Fittings Allow Integral Pipeline Adjustment
- Patented Link Check Provides Lowest Pressure Loss
- Unmatched Ease of Serviceability Available with Grooved Butterfly Valve Shutoffs
- Available for Horizontal or N Pattern Installations
- Replaceable Check Disc Rubber

The Maxim LFM500, LFM500N, LFM500Z Reduced Pressure Detector Assemblies provide protection to the potable water system from contamination in accordance with national plumbing codes. The Maxim LFM500, LFM500N, LFM500Z are normally used in health hazard applications to protect against backsiphonage, backpressure and the fouling of either check valve. The Maxim LFM500, LFM500N, LFM500Z are used to monitor unauthorized use of water from the fire protection system.

Specifications

The Lead Free* Reduced Pressure Detector Assemblies shall consist of two independent Link Check modules, a differential pressure relief valve located between and below the two modules, two drip tight shutoff valves, and required test cocks. Link Check modules and relief valve shall be contained within a sleeve accessible single housing constructed from 304 (Schedule 40) stainless steel pipe with groove end connections. Link Checks shall have reversible elastomer discs and in operation produce drip tight closure against the reverse flow of liquid caused by backpressure or backsiphonage. The bypass assembly consists of a meter registering either gallon or cubic feet measurements, a Reduced Pressure Zone Assembly and required test cocks. Assembly shall be Maxim LFM500, LFM500N, LFM500Z as manufactured by the Ames Company.

NOTICE

The information contained herein is not intended to replace the full product installation and safety information available or the experience of a trained product installer. You are required to thoroughly read all installation instructions and product safety information before beginning the installation of this product.

*The wetted surface of this product contacted by consumable water contains less than 0.25% of lead by weight.

Job Name _____ Contractor _____

Job Location _____ Approval _____

Engineer _____ Contractor's P.O. No. _____

Approval _____ Representative _____

Configurations

- Horizontal
- “Z” pattern horizontal
- “N” pattern horizontal

Materials

- Housing & Sleeve: 304 (Schedule 40) Stainless Steel
- Elastomers: EPDM, Silicone and Buna ‘N’
- Link Checks: Noryl®, Stainless Steel
- Check Discs: Reversible Silicone or EPDM
- Test Cocks: Lead Free* Cast Copper Silicon Alloy
- Pins & Fasteners: 300 Series Stainless Steel
- Springs: Stainless Steel

Available Models

OSY - UL/FM outside stem and yoke resilient seated gate valves

BFG - UL/FM grooved gear operated butterfly valves w/tamper switch

†OSY FxG - Flanged inlet gate connection and grooved outlet gate connection

†OSY GxG - Grooved inlet gate connection and flanged outlet gate connection

†OSY GxG - Grooved inlet gate connection and grooved outlet gate connection

Available with grooved NRS gate valves - consult factory*

Post indicator plate and operating nut available - consult factory*

†Consult factory for dimensions

Pressure — Temperature

Temperature Range: 33°F – 110°F (5°C – 43°C)

Maximum Working Pressure: 175psi (12.06 bar)

Dimensions — Weights

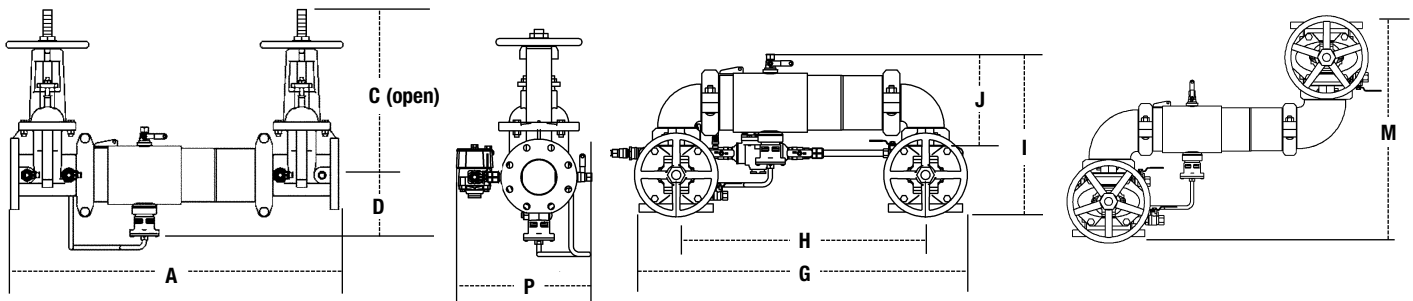

LFM500, LFM500N, LFM500Z

SIZE		DIMENSIONS										WEIGHT									
in.	A in. mm	C (OSY) in. mm		D in. mm		H in. mm		I in. mm		P in. mm		M in. mm		G in. mm		J in. mm		M500 lbs. kgs.		M500N lbs. kgs.	
2½	30¾/4 781	16¾/8	416	6½/2	165	21½/2	546	15¾/16	395	13¾/8	340	21¼/4	540	29½/2	749	8½/16	223	142	64	150	68
3	31¾/4 806	18¾/8	479	6½/16	170	22¼/4	565	16¼/4	413	14½/16	372	23	584	30½/2	775	9¾/16	233	162	73	175	79
4	40½/2 1029	22¾/4	578	8	203	30¼/4	768	19½/16	500	15¾/16	389	26¼/4	667	39¾/4	1010	11	280	236	107	259	117
6	47¾/4 1213	30¾/8	765	9½/2	241	37½/2	953	23¾/16	605	19½/2	495	34¼/4	870	49	1245	14¾/16	360	407	185	447	203
8	54¾/4 1391	37¾/4	959	10½/2	267	45¾/8	1146	27¾/16	690	21¾/8	549	36¾/8	937	59¾/8	1502	16¾/4	425	581	264	657	298
10	57¾/4 1467	45¾/4	1162	11¾/16	284	49½/2	1257	32½/2	825	24¾/16	617	44½/2	1124	66	1676	17¾/16	440	798	362	968	439

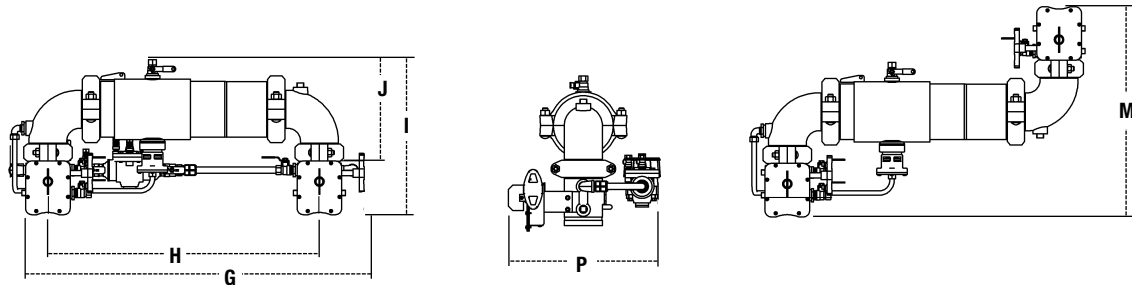

LFM500NBFG, LFM500ZBFG

SIZE	DIMENSIONS						WEIGHT							
in.	H in. mm		I in. mm		P in. mm		M in. mm		G in. mm		J in. mm		lbs.	kgs.
2½	23	584	15½/16	398	11½/16	300	19¾/4	502	31½/16	811	9½/2	242	81	37
3	24	610	16¾/16	415	12½/8	308	21¼/4	540	33¾/16	846	10½/16	255	84	38
4	30¼/4	768	18¾/16	466	13½/16	454	23½/2	597	42	1067	12	305	159	72.1
6	37½/2	953	21¾/4	553	16¾/16	418	27¼/4	692	50¾/16	1291	15¾/16	386	268	121.5

Noryl® is a registered trademark of SABIC Innovative Plastics™.

Approvals



For additional approval information please contact the factory or visit our website at www.amesfirewater.com

Flow capacity chart identifies valve performance based upon rated water velocity up to 25fps

- Service Flow is typically determined by a rated velocity of 7.5fps based upon schedule 40 pipe.
- Rated Flow identifies maximum continuous duty performance determined by AWWA.
- UL Flow Rate is 150% of Rated Flow and is not recommended for continuous duty.
- AWWA Manual M22 [Appendix C] recommends that the maximum water velocity in services be not more than 10fps.

Capacity

UL/FM Certified Flow Characteristics
Flow characteristics collected using butterfly shutoff valves.

— Horizontal — N-Pattern - - - - Z-Pattern

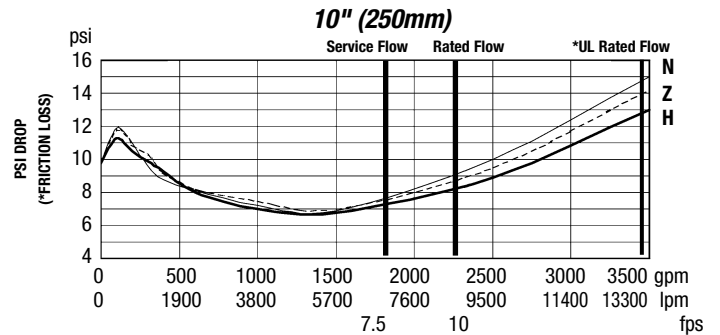
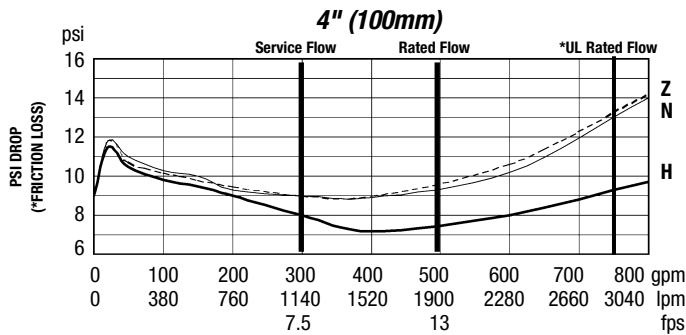
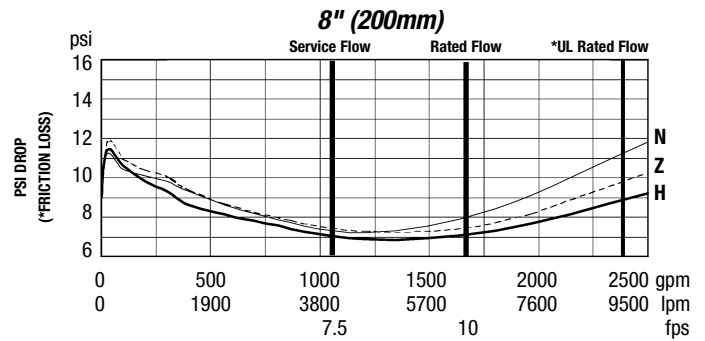
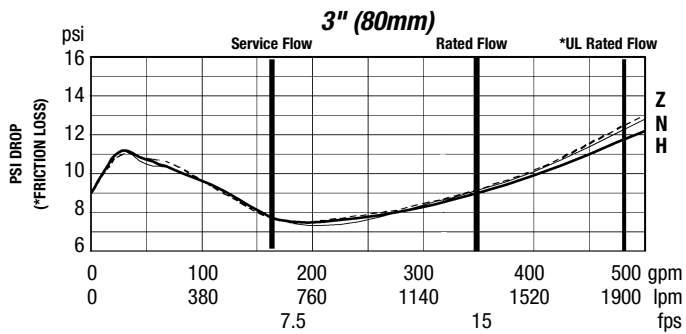
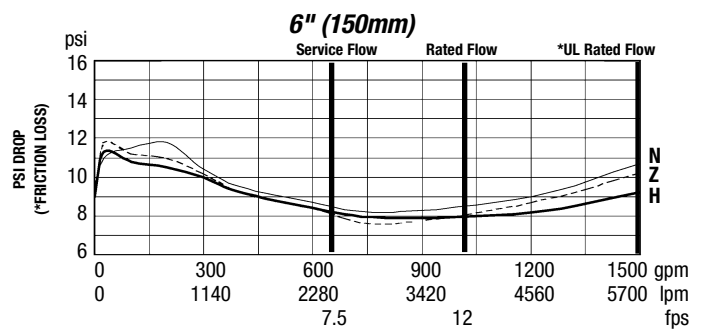
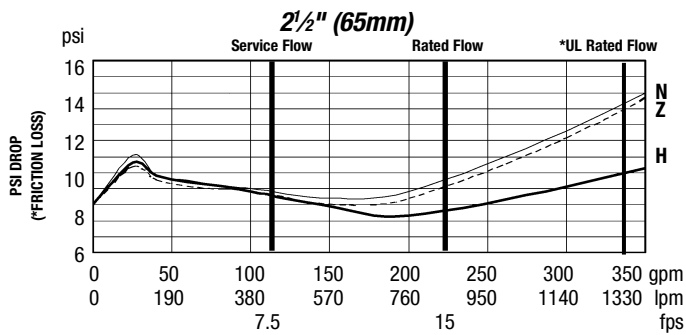

NOTICE

Inquire with governing authorities for local installation requirements



A Watts Water Technologies Company

USA: Backflow Tel: (978) 689-6066 • Fax: (978) 975-8350 • AmesFireWater.com
USA: Control Valves Tel: (713) 943-0688 • Fax: (713) 944-9445 • AmesFireWater.com
Canada: Tel: (905) 332-4090 • Fax: (905) 332-7068 • AmesFireWater.ca
Latin America: Tel: (52) 81-1001-8600 • Fax: (52) 81-8000-7091 • AmesFireWater.com