

LEAD FREE*

MasterSeries® LF856

Double Check Detector Backflow Prevention Assemblies (Type II)

Size: 2½" - 10"

The FEBCO MasterSeries LF856 Double Check Detector Assemblies are designed to protect drinking water supplies from dangerous cross-connections in accordance with national plumbing codes and water authority requirements for non-health hazard non-potable service applications such as irrigation, fire line, or industrial processing. This Backflow Assembly is primarily used for protection of drinking water systems and fire sprinkler systems, where Local Governing Code mandates protection from non-potable quality water being pumped or siphoned back into the potable water system.

Features

Main Valve:

- Inline Serviceable Assembly
- No Special Tools Required for Servicing
- Captured Modular Spring Assembly
- Reversible & Replaceable Discs
- Field Replaceable Seats
- Ductile Iron Valve Body Design
- Stainless Steel Check Components
- Winterization feature with disc retainers and valve body drain ports
- Clapper Check Assembly
- Commonality between 1st & 2nd Check Components
- Captured O-ring Design

Auxiliary Bypass:

- Compact Bypass Design; Remains within Main Valve Assembly Profile
- Inline Serviceable ¾" Backflow Assembly
- No Special Tools Required for Servicing
- Field Replaceable Seats & Discs
- Detect Potential Underground Water Leaks
- Detect Unauthorized Water Usage

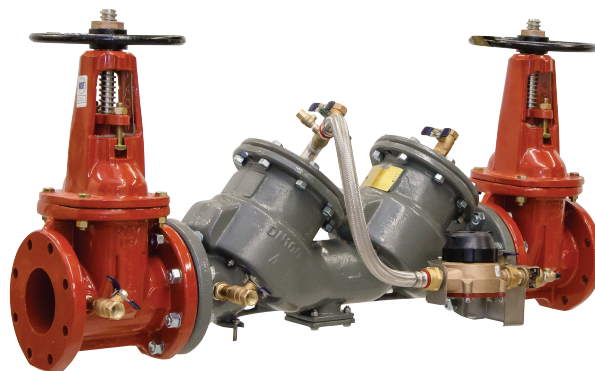

Model LF856 Double Check Detector Assembly

Specifications

The FEBCO MasterSeries LF856 Double Check Detector Valve Assembly shall be installed on the potable water supply and at each point of cross-connection to protect against possible backpressure and backsiphonage conditions for non-health hazard (i.e., pollutant) applications. The assembly shall consist of a main line valve body composed of two (2) independently acting approved clapper style check modules with replaceable seats and disc rubbers. Servicing of both check modules does not require any special tools and are accessed through independent top entry covers. This assembly shall be fitted with approved UL/FM inlet/outlet resilient seated shutoff valves and contain four (4) properly located resilient seated test cocks as specified by AWWA Standard C510. The auxiliary bypass line contains a 5/8" x 3/4" (16 x 19mm) Water Meter that complies with ANSI/AWWA Standard C700 coupled with an approved check assembly. The bypass line is designed to detect leaks or unauthorized water usage of the water system while protecting against possible backpressure and backsiphonage conditions for non-health hazard (i.e., pollutant) application. Flow and pressure loss performance parameters shall meet the requirements of AWWA Standard C510.

NOTICE

The information contained herein is not intended to replace the full product installation and safety information available or the experience of a trained product installer. You are required to thoroughly read all installation instructions and product safety information before beginning the installation of this product.

***The wetted surface of this product contacted by consumable water contains less than 0.25% of lead by weight.**

Job Name _____

Contractor _____

Job Location _____

Approval _____

Engineer _____

Contractor's P.O. No. _____

Approval _____

Representative _____

Options - Suffix

OSY: UL/FM Approved OS&Y Gate Valves
(ANSI/AWWA C515 Compliant)

CFM: Totalizing Cubic feet/min 5/8" x 3/4" Water Meter
(ANSI/AWWA C700 Compliant)

GPM: Totalizing Gallons/min 5/8" x 3/4" Water Meter
(ANSI/AWWA C700 Compliant)

LG: Less Shutoff valves; This is NOT an APPROVED ASSEMBLY

Example Ordering Descriptions:

4" LF856-OSY-GPM - Valve Assembly fitted with OS&Y Shutoff Valves & Gallon Feet per Minute Water Meter

4" LF856-OSY-CFM - Valve Assembly fitted with OS&Y Shutoff Valves, Cubic feet per Minute Water Meter

Assembly Flow Orientation:

- Horizontal & Vertical Up (2½" - 10") - Approved by FCCCHR-USC, ASSE, cULus, FM, IAPMO

Materials

Below is a general material list of the Model LF856. All assemblies' size 2½" through 10" is similar in materials and construction. Please contact your local FEBCO Representative if you require further information.

Main Valve Body: Ductile iron Grade 65-45-12

Coating: Fusion epoxy coated internal and external
AWWA C550

Shutoff Valves: OS&Y resilient wedge gate valves AWWA C515 (UL/FM)

Check Seats: Stainless Steel

Disc Holder: Stainless Steel

Elastomer Disc: Silicone

Spring: Stainless Steel

Clamp: AWWA C606 (10" Only)

Approvals

- Approved by the Foundation for Cross-Connection Control and Hydraulic Research at The University of Southern California (FCCCHR-USC)
- ASSE 1048 Listed
- **UL Classified (US & Canada)
- **FM Approved
- IAPMO
- AWWA Standard C510 Compliant
- End Connections: Compliant to ASME B16.1 Class 125 & AWWA Class D Flange

**Assembly configured with UL/FM Approved OS&Y RW Gate Valves. Less gate valve assemblies are not UL/FM approved configurations.



Pressure - Temperature

Max. Working Pressure: 175 psi (12.1 bar)

Min. Working Pressure: 10 psi (0.7 bar)

Hydrostatic Test Pressure: 350 psi (24.1 bar)

Hydrostatic Safety Pressure: 700 psi (48.3 bar)

Temperature Range: 33°F - 140°F (0.5°C- 60°C) Continuous

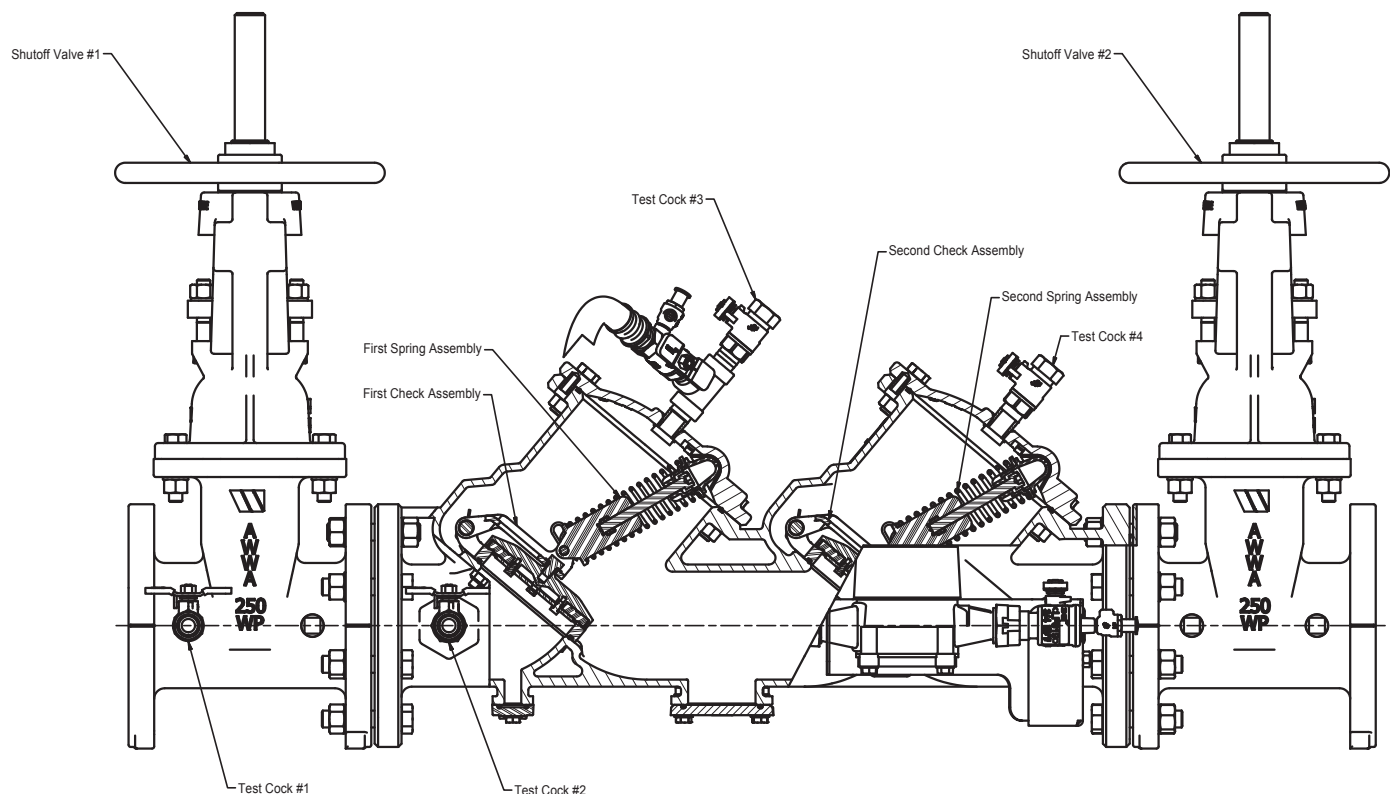

Dimensions & Weights

Below are the nominal dimensions and physical weights for the Model LF856 size 2½" through 10". Allowances must be made for normal manufacturing tolerances. Please visit our website to download a copy of this product's installation instructions, or contact your local FEBCO Representative for more information.

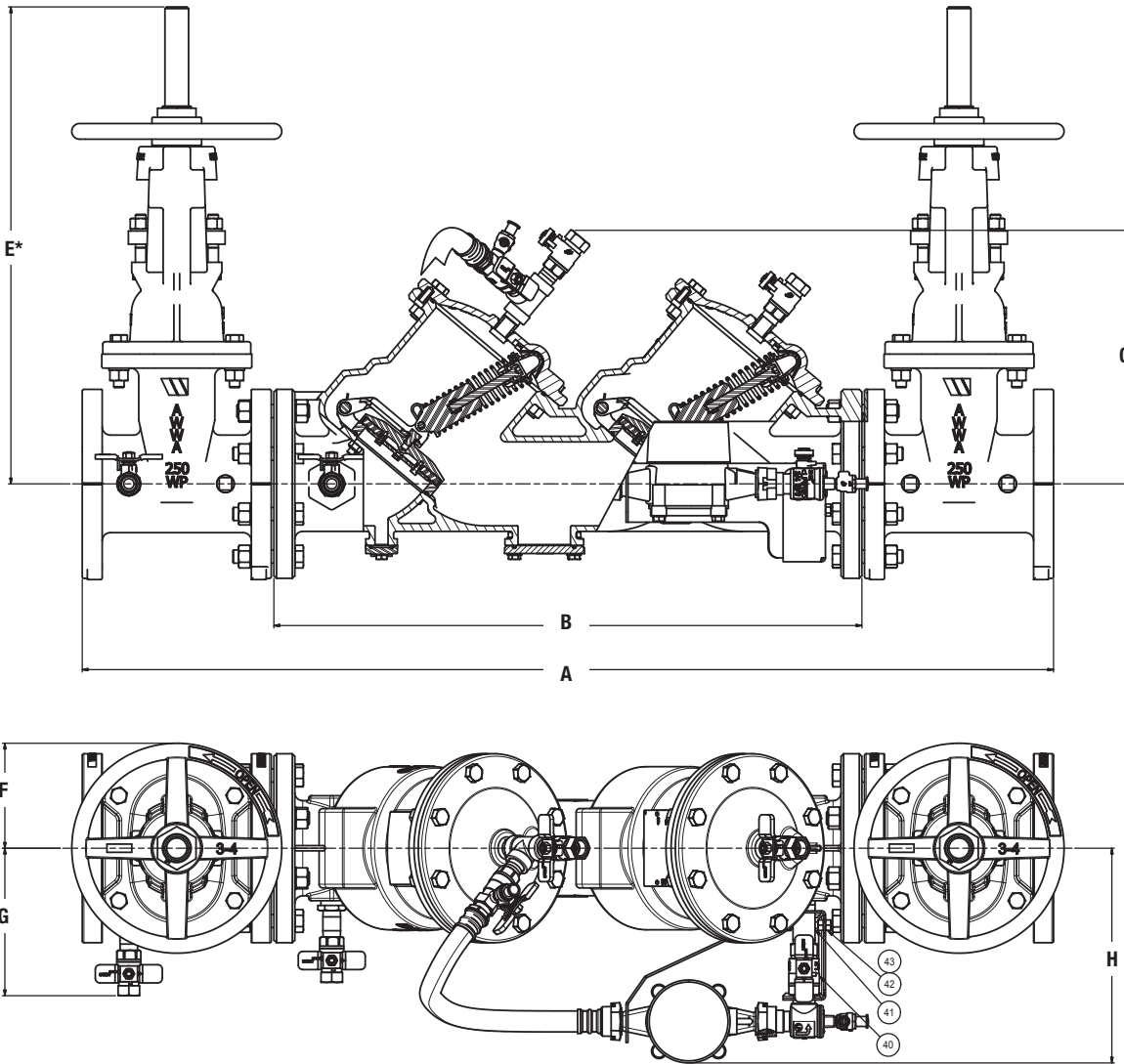

Model LF856 Assemblies

SIZE	DIMENSIONS														WEIGHT***	
	A		B		C		E**		F		G		H		OSY	
	in.	mm	in.	mm	in.	mm	in.	mm	in.	mm	in.	mm	in.	mm	lbs.	kg.
2½	40¾	1035	25½	648	10	254	16⅝	416	4½	114	7⅛	181	13⅜	340	245	111
3	41⅞	1064	25⅝	651	10	254	22⅞	565	4½	114	7⅞	187	13⅜	340	271	123
4	46¼	1175	28	711	10⅞	257	23¼	591	5½	140	8⅞	206	14	356	338	153
6	56	1422	34¾	883	12¾	324	30⅞	765	6½	165	9⅞	251	15	381	515	234
8	65	1651	41¾	1061	15⅞	397	37¾	959	7	178	11⅞	283	15¾	400	826	375
10	72⅞	1845	46⅞	1178	15⅞	397	48	1219	9	229	12⅞	314	15¾	400	1234	560

** Indicates nominal dimensions with OSY Gate Valves (Full Open Position)

*** Indicates weight of complete Backflow Assemblies with specified Gate Valves

Performance

Flow capacity chart identifies valve performance based upon rated water Velocity up to 20fps.
Velocity up to 20fps.

- Maximum service flow rate is determined by maximum rated Velocity of 7.5fps.
- AWWA Manual M-22 (Appendix C) recommends that the maximum water Velocity in the services be not more than 10fps.
- UL flow rate is determined by typically rated Velocity of 15 feet/sec.

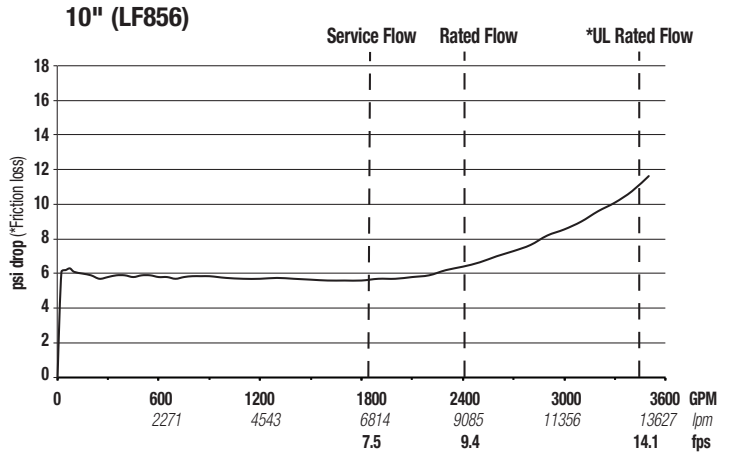
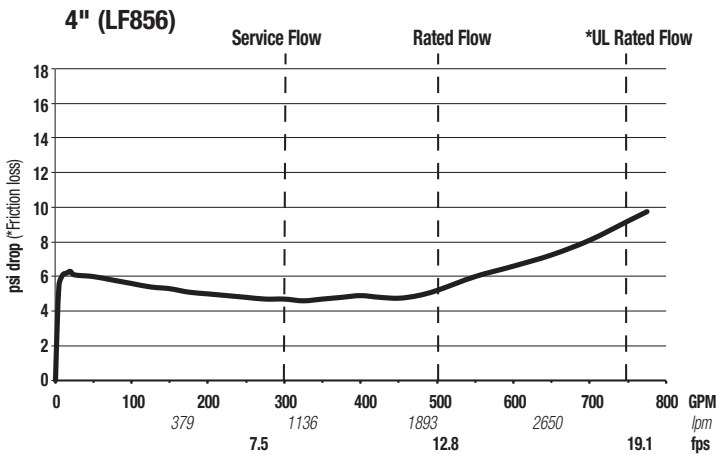
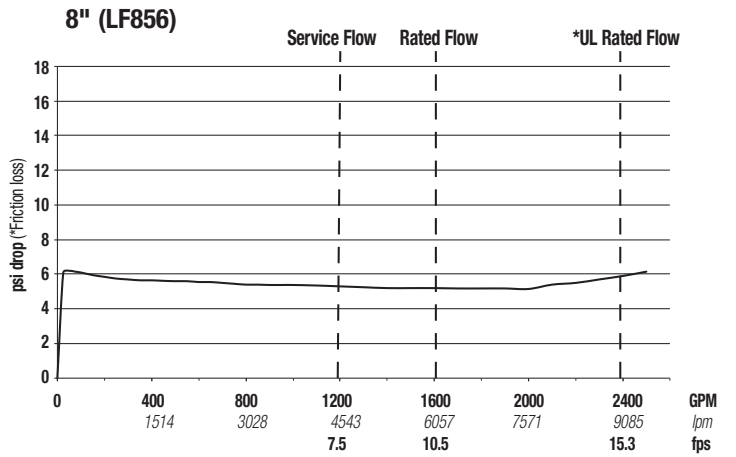
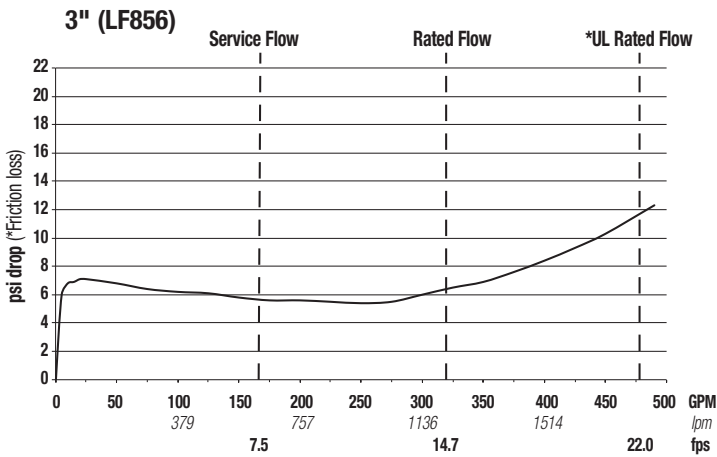
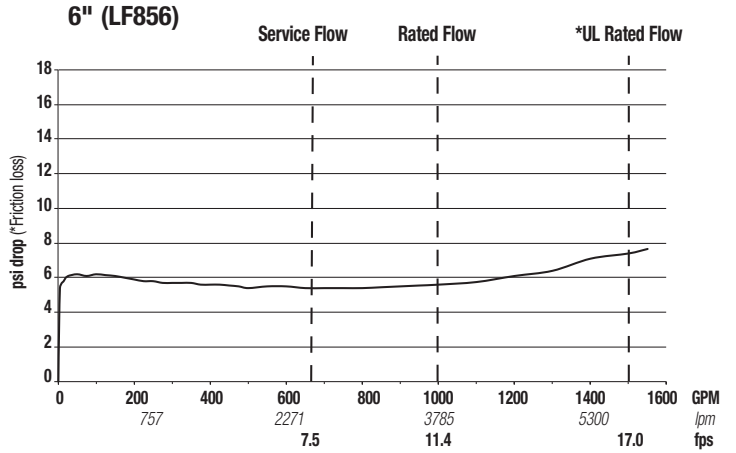
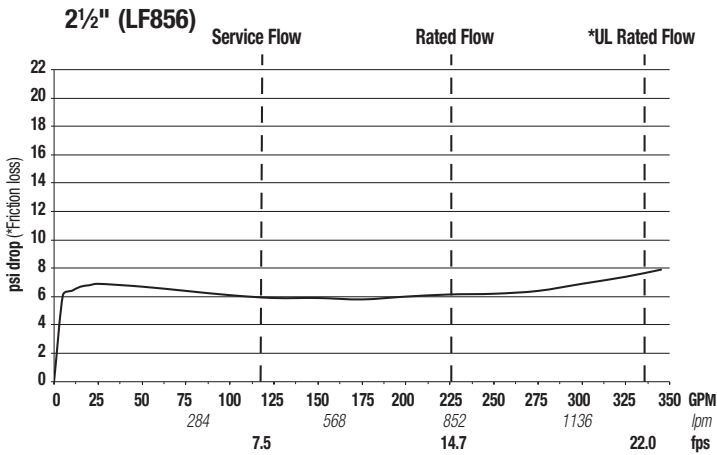

A Watts Water Technologies Company



USA: Tel: (800) 767-1234 • Fax: (800) 788-4491 • FEBCOonline.com
 Canada: Tel: (905) 332-4090 • Fax: (905) 332-7068 • FEBCOonline.ca
 Latin America: (52) 81-1001-8600 • Fax: (52) 81-8000-7091 • FEBCOonline.com